



EFFI-CYCLE

>>>DRIVE THE FUTURE<<<

Power Enhancement Season

RULE BOOK

Conventional Efficycle Format



This page is intentionally left blank.

SAE NIS EFFI-CYCLE 2022

Contents

Section A- General Guidelines

Section B- Vehicle Requirements

Section C- Driver Rules

Section D- Reports & Inspections

Section E- Events and Procedures

Section F- Documents Required During Competition

Section G- Contact Details

This page is intentionally left blank.

SECTION A- GENERAL GUIDELINES

1 Overview

1.1 Introduction

Efficycle is an intercollegiate design competition which is intended to engage engineering students in developing the eco-friendly future mobility solutions for India. The event gives participant a challenge of conceptualizing, designing and fabricating an electrically assisted-human powered, 3-wheeled, 2-seater vehicle. The competition calls participation of undergraduate and graduate engineering students from the institutes and universities across the country. The students participate in competition in form of a team guided by the faculty advisor recognized by the institute or university. Teams are expected to apply engineering concepts in developing the innovative designs of Efficycle as they have to tackle real world engineering problems, practice design for manufacturability and manage a full product life-cycle development.

1.2 Purpose

Teams are given a challenge to design a vehicle which can be utilized in real world applications e.g. for last mile connectivity and short transits in day-to-day mobility. The vehicle designed for this purpose must be aerodynamic, highly engineered, safe and ergonomic. It should be capable to be driven simultaneously as well as alternatively by two drivers and also simultaneously and alternatively on electric and human power.

Teams can consider themselves working for a fictitious firm manufacturing the vehicles (Efficycle) at mass production level. Hence the design should be commercially viable as a market product and should be attractive to the consumers because of its visual appearance, performance, reliability and ease of operation.

1.3 Competition Summary

The Competition includes designing, fabricating and validating the vehicle developed by them according to this rulebook. The vehicle would be evaluated for its design, performance, safety, durability and commercial viability. All participating teams compete against each other where the cumulative scores of all the events would decide the overall ranking of the teams. Also, the best performances of each category of evaluations are awarded.

1.4 Vehicle Design, Analysis, and Construction

The research, analysis design, fabrication and validation of the vehicle must be performed solely by a team constituting current SAE INDIA student members of that college/university. Internal or External fabrication assistance is allowed only for those things which require specialized operations. Use of sound engineering practices is expected in design and manufacturing of the vehicle.

2 SAE NIS Effi-Cycle Rules and Organizing Authority

2.1 Authority of the Rules

The SAE NIS Efficycle Rules are the responsibility of the Efficycle Technical Committee and are issued under the authority of SAE NIS. Official announcements from the Efficycle Technical Committee shall be considered part of rules and shall have the same validity as rulebook even if these were not initially included in the rulebook but communicated separately. Ambiguities or questions concerning the meaning or intent of these rules will be resolved by the Efficycle Technical Committee only.

2.2 Rules Validity

The SAE NIS Efficycle Rules posted on the event website and dated for the calendar year 2022 of the competition are the rules in effect for the competition.

2.3 New Rules for Efficycle-2022 Competition!!

This is Seventh consecutive season in the series of theme based Efficycle Competitions as following:

1. Efficycle 2015: **Light Weight Season**
2. Efficycle 2016: **Build Quality Season**
3. Efficycle 2017: **Drive Excellence Season**
4. Efficycle 2018: **Dynamic Resilience Season**
5. Efficycle 2019: **Technological Advancement Season**
6. Efficycle 2020: **E-Mobility Season**
7. Efficycle 2021: **Power Enhancement Season [Virtual]**
8. Efficycle 2022: **Power Enhancement Season**

Taking forward Efficycle on the path of technical improvements, Efficycle 2022 is being organized as *Power Enhancement Season*. A completely new fully electric variant has been introduced in Efficycle under “Advanced Category” to encourage the electric mobility. The full electric variant is not available under “Conventional Category”. Some major and minor changes are introduced in this document. Hence, teams must consider the rules given in this document only as effective rules for *Power Enhancement Season*.

Teams must try to design and fabricate a vehicle which has excellence dynamic behavior and stability on smooth horizontal roads as well as on grades, corners and rough terrains. Ride Quality & Comfort along with overall dynamic performance will be observed through various static checks and dynamic events in this season. However, focus on light weight and build quality parameters will continue.

Vehicles may be checked rigorously to evaluate the build quality of the vehicles before presenting them to dynamic events. Build quality shall be considered as an overall combination of multiple parameters including but not limited to structural quality/strength, vehicle overall configuration, ergonomic design and aesthetic presentation etc.

DO NOT ATTEMPT to design your vehicle as per the rules of any previous season.

2.4 Rules Compliance

By entering SAE NIS Efficycle competition, the team, members of the teams as individuals, faculty advisors and other associated personnel agree to comply with and be bound by these rules, all the rule interpretations or procedures issued or announced by SAE NIS, Efficycle Organizing Committee and Efficycle Technical Committee. All team members, faculty advisors and other associated representatives are required to cooperate with and follow all instructions from competition organizers, officials and judges.

2.5 Understanding the Rules

Teams are themselves responsible for reading, interpretation and understanding the rules of the competition. To seek the clarifications regarding the rules, teams should contact Efficycle Technical Committee at efficycle.technical@saenis.org. Teams must keep the records of all such email communications ready for reference of judges/inspectors during the event.

2.6 Participating in the Competition

Teams, their members as individuals, faculty advisors and other representatives of a registered college who are present on-site at a competition are considered to be “Participating in the Competition” from the time they arrive at the event site until they depart from the site at the conclusion of the competition or earlier by withdrawing. Hence all such individuals will be bound by the event rules effective for the current season.

2.7 Violations on Intent & Misinterpretation

The violation on intent of a rule will be considered a violation of the rule itself. Questions about the intent or meaning of a rule may be addressed to the Efficycle Technical

Committee. **If the team wants to use some particular parts/methods/procedures which are not included in the rulebook directly or indirectly, teams must get a clarification from Efficycle Technical Committee. Special permissions (through emails only) may be given in some cases upon the discretion of the committee. Without the permission of committee, teams are not permitted to use such parts/methods/procedures etc. and the usage shall be considered as violation of rules.**

2.8 Official Communication

All teams must pay attention to the official announcement made by Efficycle Organizers. All official announcements will be posted on website <http://effi.saenis.org> and/or at official Facebook Group www.facebook.com/groups/EfficycleSAENIS. Event organizers or Efficycle Technical Committee may directly communicate to teams/captains/faculty advisors to provide any additional information.

Following are the official email IDs for the communication with competition organizers:

1. efficycle.technical@saenis.org: for technical queries, rules clarifications, event procedures etc.
2. efficycle.teams@saenis.org: for general queries regarding team registrations, fees submission etc.

Communication with any individual event organizers through email, phone calls or social media will not be considered as official communication and will not hold any validity for competition purpose.

2.9 Right to Impound

Efficycle Technical Committee reserves the right to impound any on-site registered vehicle at any time during the competition for inspection and examination by the organizers, officials and technical inspectors.

2.10 General Authority

SAENIS and the competition organizers reserve the right to revise the schedule of the competition and/or interpret or modify the competition rules at any time and in any manner that is in their sole judgment, required for the efficient and smooth operation of the event.

3 Eligibility

3.1 Eligibility Limits for Teams

Eligibility is limited to undergraduate and graduate engineering students to ensure that this is an engineering competition rather than a race.

3.1.1 Student Status

Team members must be enrolled as degree seeking undergraduate or graduate students in same campus of a college, institute or university situated in India. Team members who have graduated during the seven (7) month period prior to the last date of competition remain eligible to participate.

3.1.2 Team Size

A group of minimum 5 to maximum 13 student members can register as a team. The team may contain students from any engineering discipline.

3.1.3 SAE Membership

Team members, faculty advisor and other representative must be member of SAE INDIA at the time of competition.

3.1.4 Age

Team members must be at least eighteen (18) years of age at the time of event.

3.1.5 Driver's License

Team members (at least 2) who will drive the vehicle at any time during the competition must hold a valid, government issued 2W/4W driver's license.

3.1.6 Liability Waiver

All on-site participants, including students, faculty advisors and all other representatives of team are required to sign a liability waiver upon registering on-site.

3.1.7 Medical Insurance

Individual medical/health insurance coverage is required for at least 2 team members designated for driving the vehicle during competition and it is the sole responsibility of the participants. No medical insurance will be provided by Efficycle Organizers or by SAE NIS. No claim by participants will be entertained in this regard at any stage of the event.

3.2 Faculty Advisor

3.2.1 Status

Each team is supposed to have a Faculty Advisor appointed by the college/university. The Faculty Advisor is required to accompany the team to the competition and will be considered by competition officials as the official college/university representative. Faculty Advisor must have a valid SAE India membership.

3.2.2 Responsibilities

Faculty Advisors may advise their teams on general engineering and engineering project management theory and act as guide of team. The Faculty advisors are allowed to attend static & dynamic events along with their team at event site but will not be allowed to provide answers or justifications for any question on behalf of team.

3.2.3 Limitations

Faculty Advisors should not design any part of the vehicle nor directly participate in the development of any documentation or presentation. Additionally, Faculty Advisors may not fabricate nor assemble any components, nor assist directly in the preparation, maintenance or operation of the vehicle. But they can support their team for proper upkeep of vehicle in case of any breakdown.

He/she can also not perform in the dynamic event on behalf of the team members. It is also recommended that all documentation of team should be verified by the Faculty Advisor.

3.3 Registration Procedure:

3.3.1 Team Registration for Participation in competition

Team registration will be through online portal after the announcement of event.

3.3.2 Event Site Registration

The teams shall mark their presence at final event by registering at event site on the Day-0 of competition.

3.3.3 Change in Team- *REVISED*

Changes in team details and event category can be performed through team's account in registration portal. These changes will be allowed from the date of team registration till 2

Months before the Starting Dates of competition. Any such changes must be informed to organizing committee by writing email to Effi-Cycle.teams@saenis.org. The copy of final registration form should be submitted to Effi-Cycle.teams@saenis.org after approval from institute authorities (HOD/Dean/Director).

Any changes in the team will not be allowed after the above mentioned deadline. However any critical issues related to team structure, captain or faculty advisor at any stage of the event may be brought notice to Effi-Cycle Organizing Committee at Effi-Cycle.teams@saenis.org with prior approval from institute authorities.

3.3.3.1 After 30th April of competition year, If there is any requirement of changes in team, first a written permission must be taken from Head of Department/Dean/Director of the institute on college letter head and should be sent to Organizing Committee.

3.3.3.2 These issues will be reviewed by Organizing Committee for further decisions. *Please note that this letter is required to only put up the issue in consideration of organizing committee and Efficycle Organizing Committee reserves its rights to disregard such requests.*

3.4 Vehicle Shipping

The teams must ensure that their shipping agency or freight forwarder or commercial carrier complies with all the rules laid down by the government for inter-state transportation. The vehicle shipping may be a complex and lengthy process. It is the responsibility of teams to ship the vehicle on proper time so that it reaches the event-site before start of event. The participating team itself must be listed as receiving party of consignment. Neither event organizers/SAE NIS nor the host institute can be listed as receiving party.

Teams must keep proper care during transport to avoid any damage to the vehicle. A proper care must be taken while selecting the mode of shipping (train/truck etc.)

3.5 Maximum Entries per college

Multiple teams from any college/university may register for the event. Multiple teams cannot have any team member or faculty advisors in common.

3.6 Eligibility for Participation in Main Event

There will be no Virtual Qualifier Round for main event in the Efficycle 2022 event. The performance of all teams will be monitored throughout the season. This monitoring will be done by several means such as reports submission, direct discussion with the team members or faculty advisors, college level visits and inspections. If any team is found not meeting the project activity timelines, it may be barred from main event as per rule 7.5.

4 Vehicle Eligibility

4.1 Student Developed Vehicle

Vehicles entered competitions must be conceived, designed, fabricated and maintained by the student team members without direct involvement of professionals, automotive engineers, racers, professional fabricators, technicians, machinists or related professionals.

4.2 Second Year Vehicles

Vehicles, which have participated in SAENIS Efficycle 2019 competition first time, are eligible to participate in the event. However, the vehicle will be subjected to technical inspection during the competition as per 2022 rules.

It is expected from the teams, opting for second year vehicle, to carry out significant improvements in the vehicle. These vehicles may be subjected to strict inspection and static & dynamic evaluations.

Teams, willing to use the second year vehicles, must write to Efficycle Technical Committee latest by 30th June 2022.

4.3 Information Sources

The student team may use any literature or references related to vehicle design and information from professionals or from academics as long as the information is given as a part of discussion of available alternatives with their pros and cons.

4.4 Professional Assistance- *Prohibited*

Professionals should not make design decisions, drawings or fabricate the vehicle. Those vehicles found to be professionally made will be disqualified from the competition and that college/university will suffer a ban of next 1 more year from participating in the event.

4.5 Kit Vehicles- *Prohibited*

Vehicles fabricated from a kit or published designs are ineligible to compete.

4.6 Student Fabrication

Efficycle is intent of the SAE Collegiate Design Series competitions to provide direct hands-on experience to the students. Therefore, students should themselves perform all fabrication tasks whenever possible.

4.7 Proof of In-house Vehicle Fabrication

Proof of fabrication of the vehicle in college facility will be required in form of photos, videos taken during the each stage of fabrication of vehicle (e.g. prototyping, fabrication of components, frame, seats and assembly etc). It is solely the team's responsibility to produce all such document when asked by the event organizers.

Permission of College to use workshop facility for fabrication purpose is also required. This permission letter should be submitted as part of document package.

4.8 Limitation on Fabrication at External Facilities

Only those components, which require special tools/machinery for the fabrication, can be allowed for fabrication from external facility. Bills, Invoices, Machinery Rent Receipt along with College/Faculty Advisors Permission will be required as a proof of such works.

4.9 Previously Participated Teams

Efficycle is intended for putting genuine design efforts in conceptualizing the efficycle. Hence the teams which have been participating in the previous seasons of event must incorporate significant improvements in their design with proper justification. This doesn't include the changes enforced by update in rules. However, it is subjected to the decision of judges during evaluation.

SECTION B - VEHICLE REQUIREMENTS

5.1 Vehicle Configuration

The vehicle must have three wheels that should not be in a straight line (i.e. tandem configuration is **prohibited**). The vehicle must be capable of carrying two riders, of at least of 1905 mm (6'3") height and weighing 115 kg each and a payload of 20kg. The vehicle can have only tadpole (2F1R) configuration.

5.2 Vehicle Dimension

Vehicle can have a maximum width of 60 inches (1524mm) covering all its rigid or movable projected parts. Length of the vehicle is not restricted but it is recommended to be within 100 inches (2540mm).

5.3 Vehicle Weight

Efficycle is intended for building vehicles with least weight. Teams are encouraged to follow light weight practice during design stage and to use light weight components, materials and systems in the vehicle.

Maximum recommended Efficycle Kerb Weight is 150kg. The teams having vehicle weight within 120kg will be considered for **Light Weight Score**.

5.4 Vehicle Frame

5.4.1 Frame Design

The efficycle frame is the basic structure on which other subsystems are mounted. Frame should be rigid, protective and ergonomically designed. Any type of holes, cracks dents etc in frame members are forbidden.

5.4.2 Protection Offered by Frame

The frame must protect the drivers in case of collisions and breakdowns and must prevent the entry of debris/foreign particles during running conditions. **Protection for the impact from front, sides, rear and rollover are mandatory.** Severe track conditions must be taken into account while designing the frame.

5.4.2.1 Overhead protection

The overhead protection members (OHPM) must be extended *horizontally* at least 12 inches (304.8mm) forward from the center of each driver's heads (when viewed from

Note: Figure 1(a) and 1(b) are showing only 12 inch limit illustration. For illustration of Point 'B', figure-4 at page 21 must be referred.]

5.4.2.2 Cross Members and Bracing

At least two (2) Lateral Cross Members (LCMs) are required in overhead frame. First LCM should connect the outer OHPMs at the topmost point of their bend portion behind the driver's head. Second LCM should be provided at the one of the following locations:

- 24 inch (609.6 mm) forward to rear LCM or
- Within 2 inches (50.8 mm) before the termination of OHPMs; in case of open hoop
- Within 2 inches (50.8 mm) before the front bend of OHPMs; in case of close hoop

At least one **Diagonal Bracing Member (DBM)** should be given in overhead frame between the outermost OHPMs. The diagonal bracing can be joined within 4 inch (101.6 mm) from corner joints of OHPM and LCM.

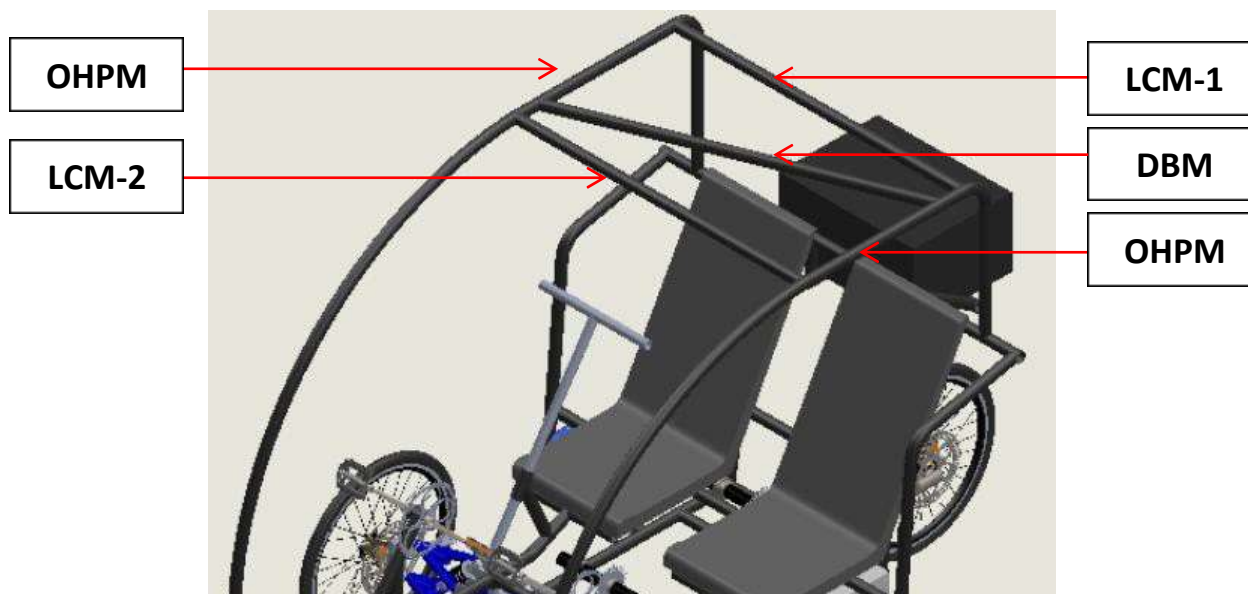

5.4.2.3 Side Protection

Side protection members (SPM) must be placed such that the drivers' bodies must be completely inside the periphery created by vehicle frame members in 3D Space. No part of the drivers' bodies including torso and head must project outside the vehicle frame periphery during static as well as running conditions. Periphery is referred to an enclosed 3D Space created by geometric planes or a surfaces passing through external edges of any 2 nearest frame members and has a complete enclosure therefore.

SPMs should be provided as a close loop and attached to the frame members behind the seats. SPM loop should be extended at least 8 inches (203.2mm) forward to the front face of seatback when measured at 16 inches (406.4mm) above Point 'A' on seat.



Figure-2(a)



Figure-2(b)

Point 'A' is defined in rule 5.6.6. Figure 2(a) is only for the illustration of SPMs

5.4.2.4 Second Rider Hand-holds

The handhold must be provided to both hands of second rider. Handholds must be inside the frame periphery such that rider needs not to hold any external frame members for support while driving. Side protection members and handholds must be placed such that these do not hinder the ingress and egress of drivers noticeably.

5.4.2.5 Front Fairing

A fairing is compulsory in front of drivers (forward to only the front driver in case of longitudinal arrangement of seating positions). The fairing must be constructed with the transparent sheet of sufficient strength which is mounted to the frame with the help of strong mounting members. This mounting may be made removable for the repairing and shipment purpose. But vehicle should always be presented with fairing for inspection.

Fairing should be extended vertically from the top of head of drivers till the seat cushion surface plane when viewed from front. It can be extended on the lower side to cover other vehicle components, if required. Horizontal edges should cover the whole width of driver seating area.

Fairing should be aerodynamically designed and can be curved in shape. It is allowed to provide sufficient access, in form of profile cut through fairing sheet, for drive train component placement and drivers' legs movement.

If the fairing is placed between the drivers and the drivetrain components projecting forward (in side view) but not at the front most position, then it is necessary to provide a drive train protection sheet of sufficient strength and area.

5.4.2.6 Rain Protection & Body Enclosures- **REVISED**

Protection of drivers from rain should be ensured by putting the full body enclosures. This means that the driver seating area should be covered from top, sides, front and rear. Any flexible, light weight but durable material can be used for this purpose. If required for better aesthetics, teams may use light weight sheet metals or sheets of plastic materials.

Body enclosures should be provided such that frame members should not be visible from outside. Sufficient area may be kept permanently open for easy entry and exit of drivers on both sides. Teams may additionally provide half doors (below driver's chest level).

Front wheels should not be visible when viewed from top while the tires are kept in straight ahead position. These should be either accommodated within the frame members or the wheel covers may be provided.

For Electric Variant: Battery, BMS and motor should be provided with rain protection to avoid entry of rain shower and splash from water on road surface. IP65 protection must be provided.

5.4.2.7 Towing Point- **REVISED**

A towing plate should be provided at the rear portion of vehicle for attaching a payload with the vehicle with the help of rope/cables/metal bars etc. The specifications of the towing plate are given below:

Parameter	Sym	Specification
Material	--	Steel
Mounting	--	Welded to
Tab Thickness	--	Min: 8 mm (0.31 in) Max: 9.5mm (0.375 in.)
Hole Diameter	D	Min: 25.4 mm (1.0 in.)
Hole-to-Tube Offset	X	Min: 19.0 mm (0.75 in.)
Edge Distance	R	Min: 15.9 mm (0.625 in.)
Width at Frame	Y	Min: 76.2 mm (3.0 in.)

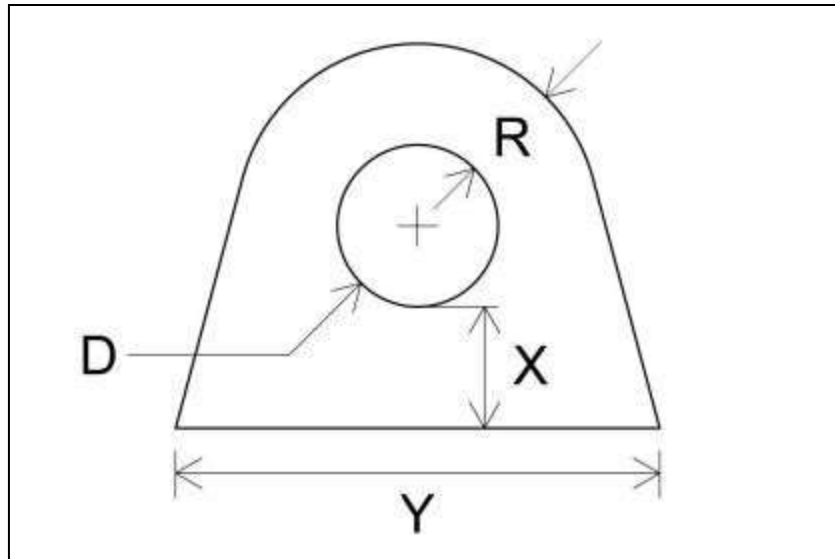

5.4.2.8 Rider Compartment Floor- **NEW**

Floor should be provided in rider compartment so that riders do not touch the ground and it they are protected from debris particles and water splash from underneath. Floor material must be metal, fiberglass, plastic, or similar material. Floor should withstand the load of the driver at all conditions. Structural members should be provided underneath at suitable locations to support the floor. Necessary cut-out for pedal and chain access may be provided in hybrid variants.

5.5 Frame Material & Cross-Section Requirements

The frame may be built up with materials or combination of materials mentioned under this rule. Use of multiple shapes, cross-sections sizes and material is allowed. Teams should work out upon the material availability, weld-ability, weight reduction, structural strength etc. For all materials used in building the frame, following criteria must be fulfilled:

“The bending strength & bending stiffness of the cross section used in frame must not be less than bending strength & bending stiffness when a circular cross section of 1 inch (or 25.4mm) outer diameter and 0.078 inch (2 mm) wall thickness with carbon percentage 0.18% is used.”

However, in any case the wall thickness below 1.5mm cannot be used even if the above criterion is satisfied. The strength of joints can be taken same as parent material.

Note:

The bending stiffness and bending strength must be calculated about a neutral axis that gives the minimum values.

- ❑ Bending stiffness is considered to be proportional to the product EI where:
 E = Modulus of elasticity (205 GPa for steels)
 I = Second moment of area for the structural cross section

- ❑ Bending strength is given by:

$$M = (S_y * I) / C$$

Where:

S_y = Yield strength (365 MPa for 1018 steel taken as reference)

C = Distance from neutral axis to extreme fibre

[Illustration:

A combination “X” of reference material & cross-section is defined in the rule having circular cross section of outer diameter = 1inch (25.4mm) and wall thickness= 0.078 inch (2mm) with carbon percentage = 0.18%.

The teams should calculate the following

- 1. Bending Strength of X = $(S_y * I) / C$ [for example, AISI 1018 with $C\% = 0.18\%$ may be taken which is having the yield strength $S_y = 365 \text{ Mpa}$]**
- 2. Bending Stiffness of X $\propto E.I$**

Now if the team is using a combination “Y” of any different material or different cross-section, then the Bending Strength & Bending Stiffness of Y must be calculated with similar procedure and compare such that:

$$\begin{array}{lcl} \text{Bending Strength of Y} & \geq & \text{Bending Strength of X} \\ \text{Bending Stiffness of Y} & > & \text{Bending Stiffness of X} \end{array}$$

5.5.1 Steel or Steel Alloys

All steel/steel alloy frame members of frame must be joined over complete run of joint using good welding practices. Joining of any two or more steel/steel alloy members together in frame with bolted application/fasteners is not allowed.

5.5.2 Using Other Metals or Composites Material

The complete frame of the partial frame may also be constructed with-

1. Metals other than steel or its alloys.
2. Composite materials
3. Combination of both (including partial usage of above with steel frame)

A bolted joint is allowed with 2 or more non-steel/alloy members or non-steel/alloy to steel/alloy members.

Teams are encouraged to work upon alternate materials for making the vehicle light weight.

5.5.3 Material Testing Report

A material testing report must have materials' Yield strength and Ultimate Tensile Strength (in MPa) for all materials used in vehicle frame. The material testing report should be prepared in the format released by organizers. Material testing may be performed in external test facility or institute's own facility. The certificate provided by material dealers will not be accepted.

5.6 Driver Seats

5.6.1 Seat Requirements

Separate seats should be provided to individual drivers. The seat shall be fastened to the frame using mounting tabs and bolting applications. Seats directly bolted to frame members are **prohibited**. Cushioning or padding attached directly to the frame will not be accepted as a seat.

Teams are encouraged to use in-house fabricated seats for overall vehicle weight reduction.

5.6.2 Thigh & Torso Supports

The seat must support the thigh and the entire torso (full width) of both the drivers. Torso support must end at maximum 2 inch (50.8mm) below the driver shoulders and it must be able to provide the support to driver torso in all static and dynamic conditions.

Refer below examples for allowed and prohibited types of seats.



Figure-3

5.6.3 Seating Configurations

Seats can be placed in any of the following configurations-

- 1) **Adjacent:** Both seats are placed side by side
- 2) **Longitudinal:** Seats are placed one after another in longitudinal direction of vehicle (Front & Rear Seat).

5.6.4 Adjustments in Seat and Seatback

Longitudinal adjustment in the seats is allowed for providing suitable adjustment for drivers of different heights. The adjustment system should have a proper locking mechanism such that it remains intact in the position of use.

Seatback may also be provided with the reclining adjustment such that it can be adjusted at different angles.

Length of Overhead protection members will be checked at foremost positions of seat and seatback such that criterion of rule 5.4.2.1 is fulfilled.

5.6.5 Seat Height (d)

Maximum height (d) of the top surface of seat cushion (measured at Point 'A' on seat cushion which is located 4 inches (101.6mm) forward to the point of intersection of seat cushion and seatback) cannot be more than 24 inches (609.6mm) from ground for both driver seats. The measurement will be taken without drivers and payload while the seat cushion is not compressed.

5.6.6 Sitting Space Height for Drivers (h_s) -

Sitting space for drivers is vertical space available between seat cushion top surface and the bottom edge of overhead protection members. This will be measured in vertical direction from Point 'A' to the point 'B' (where Point 'B' is the vertical projection of Point 'A' on the bottom edge of the overhead protection member when viewed from side). Following sitting height (h_s) must be provided according to the seatback angles (α):

Range	Seatback Angle from Vertical (α)	Sitting Space Height (h_s)	Tolerance
1.	$\alpha \leq 25$:	= 40 inch (1016mm)	± 1inch (±25.4mm)
2.	$25 < \alpha \leq 45$:	= 37 inch (939.8mm)	
3.	$45 < \alpha$	= 32 inch (812.8mm)	

If the seatbacks or suspensions are adjustable such that seatback angle is covered in more than one range, as given in above table, then the sitting height should be taken according to least possible seatback angle.

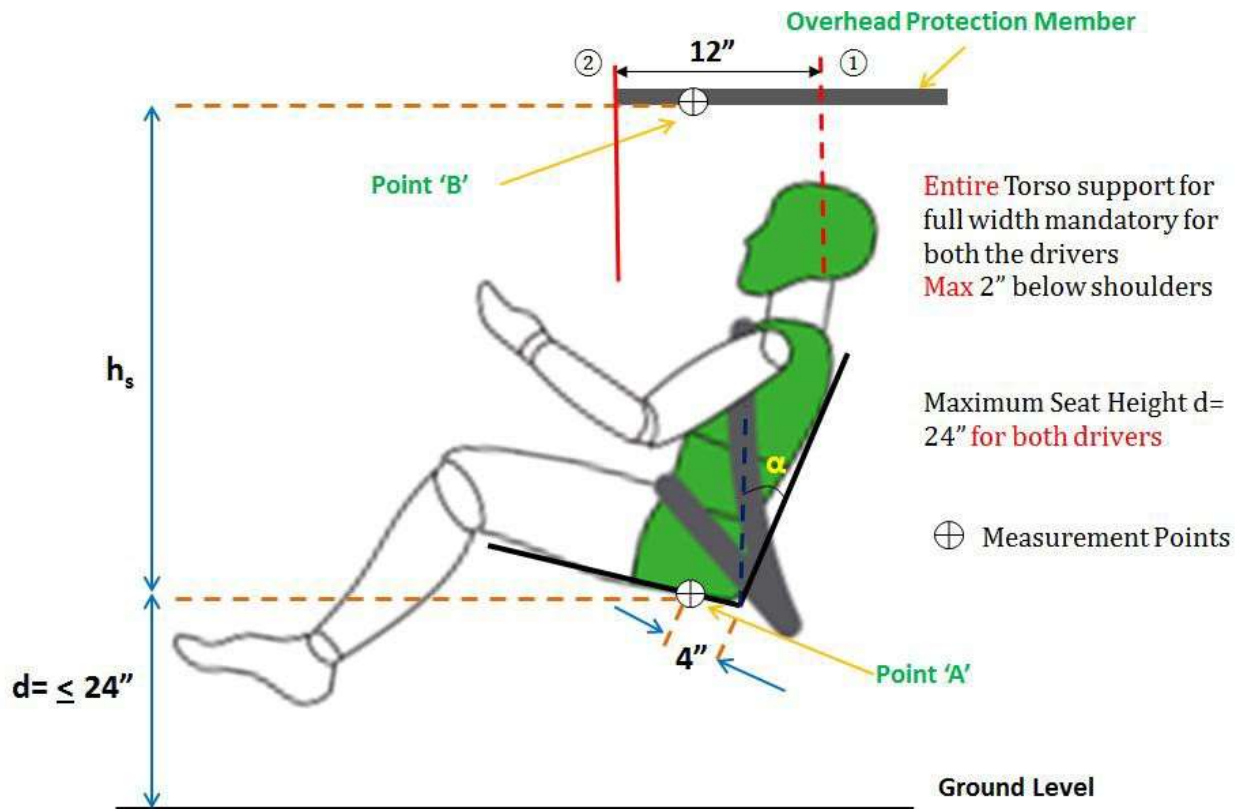

Figure-4

5.6.7 Seatback Support Member

The purpose of providing a seatback support member is to have a rigid support to seatback and to restrict its movement in case of failure of seatback adjustment or locking system. It should be placed close to the seatback such that minimal gap exists in between.

If recliner seats are used, the seatback support member will be placed at the maximum possible rearward inclination of the seatback. A cross-section of sufficient strength can be used for this member and it should be welded to frame in form of linear member in transverse of vertical directions, curved member or loop etc.

5.7 Seat Belts

5.7.1 Seat Belt Requirements

Use of 3-point seat belts with retractor is mandatory for both the drivers. Use of OEM seat belts with standard buckle and mountings is recommended. Normal shoulder straps, side release buckle straps, belts with metal cam lock buckles etc. cannot be considered as seat belts. (Refer below figures).

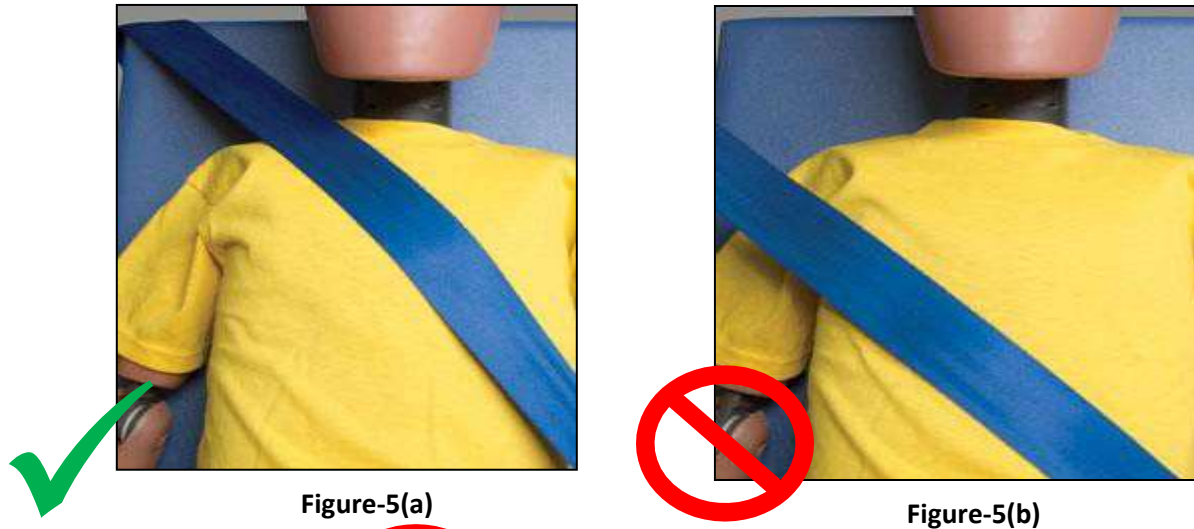

5.7.2 Seat Belt Mounting

Figure-6

Shoulder belt must be mounted behind the shoulder and minimum 4 inches (101.6mm) above the shoulder level of the drivers. The lateral distance of seat belt mounting from the longitudinal centre plane of seat must be minimum 8 inches (203.2mm) at the height of 4 inches (101.6mm) above the shoulder level.

Shoulder belts must come across the outboard shoulder of drivers and should be buckled to the lap inboard. Seat Belt movement should not be hindered by the frame members.

Standard mountings provided with the seatbelts should be used. Belts with holes, tampered webbing or tampered stitching shall not be accepted. All seat belts should be mounted with bolting on tabs fixed on frame (mandatory). Shoulder belt mounting can be placed on seatback supporting member (recommended).

5.7.3 Head Restraint

Head Restraints may be provided (not mandatory) as a separate attachment to vehicle body/frame/seat or as an integral part of seat itself (i.e. by extending the height of seatback support member).

If the head restraint is provided, the maximum clearance between the head restraint and drivers' helmet must be 1 inch (25mm). The minimum area of the head restraint should be 6 in x 6 in (152.4mm x 152.4mm).

5.8 Clearances

5.8.1 Body Clearances

Drivers' body should have a clearance (gap) of minimum 3 inches (76.2mm) with any component of the vehicle, in static and dynamic conditions. Hands, torso, thighs etc. & body parts that make contact with the vehicle in normal seating position are excluded from rule.

5.8.2 Ground Clearance

All rigid parts of the vehicle must have minimum 6 inches (152.4mm) clearance from the ground when measured with both the drivers in normal riding conditions. The measurement of ground clearance will be done at the lowest rigid parts¹ of vehicle which cannot change their position at the time of impact either without resulting in permanent failure in the subsystems or without increasing the risk of injuries to drivers and bystanders. Wheel assemblies are exempted from this rule. Wheel assembly includes all the parts directly mounted to wheel or wheel hub like brake disc, derailleur² etc.

The moving parts such as pedals etc. must have minimum 3 inches (76.2mm) from the ground at their lowest position.

5.9 Power

Vehicle must have the provision to drive it on Human power and Electrical Power both simultaneously or alternatively.

¹It may be considered that rotary parts such as pedals & cranks etc can change their positions in case of direct impact to them by ground obstacles of not more than 6 inches. Whereas chain, sprocket, derailleur etc cannot change their position, even if these are rotary/movable during operation.

²Only those derailleur are exempted which are directly mounted on wheel hub.

5.9.1 Human Power

The vehicle must have the capability to be driven by human power. Both the drivers must be provided with individual power-trains to drive the vehicle in both single passenger mode and dual passenger mode. Use of hand operated or foot operated drives or both is permitted to deliver maximum power to wheels through human powertrains.

5.9.2 Electrical Power

Vehicle must have the option to run on electrical power. **A 48V BLDC motor of maximum 600W rated power can be used for this purpose.** To provide a uniform basis to performance events, all vehicles must use the same motor. The motor kit will be provided by **Vikson India**. Internal Combustion engines and solar cells are excluded from the competition.

5.9.2.1 Acceptable Motors for Efficycle 2022

Motor Part Number: KTC600R

5.9.2.2 Motor Kit Content:

All motor kits will be provided with following contents:

- KTC 48V 600W BLDC Motor 1
- KTC 48V Controller 1
- Junction Box (Yellow) 1
- General Purpose Wiring Harness 1
- Key Switch with Meter Assembly 1
- Handle Bar Accelerator (Throttle) 1
- Chain-Sprocket Set 1

5.9.2.3 Purchasing Motor Kit

Teams must order the motors at least 4 months Prior to the Event Starting Date by direct payment to Vikson India. Teams should take care by themselves for shipment & delivery.

5.9.2.4 Purchasing Additional Motor Kit

Teams may purchase additional motor kit directly from Vikson India.

5.10 Transmission System

Transmission system is mandatory to transfer the power from motor to wheels. Use of shafts, chain-sprockets, belt-pulleys, gears and epi-cyclic gear trains & friction wheels etc. is

permitted for delivering power. The power from human and electric power-trains can be delivered to different wheels or cumulatively to same wheel/axle. Direct mounting of the motor to the wheel hub and its direct coupling to axle is **PROHIBITED**.

5.11 Battery

5.11.1 Specifications- *REVISED*

Teams can use 48V & maximum 35Ah batteries. Use of more than one battery for electric drive circuit is allowed provided that the combination (series or parallel) of batteries doesn't have the output more than the above specified range. Each battery should have the specification written on it by manufacturer only. The Ah specification (capacity) of this battery must be selected as per the consumption requirement for adding optimum weight of batteries to vehicle. The internal circuit of battery and specification sheet should be presented to judges.

5.11.2 Protection of Batteries

All batteries must be sealed and leak proof. Vehicle found with any type of leakage in batteries may be barred from participation. Proper shielding should be provided to protect batteries from water splash, dust and mud etc. In all cases safety of riders must be ensured. Short-circuit/fire/explosion prevention techniques should be applied. IP65 protection must be provided.

Teams are encouraged to use light weight batteries for overall vehicle weight reduction.

5.11.3 Mountings

Batteries should be mounted using sound engineering practices. Hung mountings are not allowed. The mounting should be able to protect batteries from falling at the time of bumps and leaning etc.

5.11.4 Batteries for Additional Circuit

Use of a separate battery/ battery bank for other electronic components such as lights, regeneration circuit etc is allowed. Teams may choose battery specification according to application. This battery should not be included in the electric powertrain circuit.

5.11.5 Battery Charging

Provision should be made to charge the batteries without removing them from vehicle. Batteries cannot be removed/ replaced after technical inspection. Teams may carry portable chargers for charging batteries in pit area. Battery charging is allowed before each dynamic event.

5.12 Energy Regeneration System- **OPTIONAL for Conventional format**

Vehicle should be equipped with an Energy Regeneration System such that the Kinetic Energy of vehicle may be converted into electrical energy which can be further stored into an electrical storage device.

For any such arrangements the teams may be asked for explanation at the time of technical inspection and design evaluation.

This requirement is optional in Efficycle 2022. However, vehicles equipped with Energy Regeneration System shall be evaluated for their regeneration capability.

5.13 Drive Train Shielding

5.13.1 Protection from Mechanical Parts

All moving parts such as belts, chain, and sprocket, must be shielded, to prevent injury to the driver or bystanders, from the metal / chips that may fly apart due to centrifugal force. These guards/shields must extend around the periphery of the belt or chain. These must be mounted with sound engineering practice, in order to resist vibration.

If pedals project towards front of the vehicle, a protection sheet of sufficient strength (metal/ non-metal) must be provided in front of pedals such that in case of any collision, these do not cause injuries to other riders, bystanders etc.

5.13.2 Electrical Shock Protection

Selection of wire diameter/cross-section must be done according to the current flow in the circuit. To avoid any short circuit, battery terminals must be shielded but should be kept accessible for the approach of any measuring instrument. All electrical connections should be properly insulated from the frame.

All wires and harnesses must be fastened securely to the vehicle structure that prevents coming off in static and dynamic conditions. Use of metal wires, synthetic threads and tapes as a fastening device is **prohibited**. The wires and cables must be routed along the frame in a flexible casing and should be tied to frame such that these do not entangle with the riders' body and other moving parts of the vehicle.

5.14 Brakes- **REVISED**

All Efficycle are required to have brakes on all wheels to ensure the maximum braking performance and safe driving conditions during the event. **Teams can use hydraulic or non-hydraulic brakes.** Brakes **MUST** be mounted on all three wheels; mounting of brakes

only on drive axles is **STRICTLY PROHIBITED**. Control of all 3 brakes must be given to primary driver who is operating the steering.

Brakes may be tested during technical inspection by pushing the vehicle in forward direction, with both the riders in normal riding positions. Drivers will be asked to apply the brakes. All wheels are required to be locked during this test. Also there will be a separate brake test according to the procedure specified in rule 8.1.4.

5.15 Steering System and its Control

Steering system must be designed such that the turning radius of vehicle is not more than 4 meter. Turning radius will be checked in 'Figure of 8' test having outer circle of 8 meter (315 inches) diameter. The steering system and control should be ergonomically designed.

Steering control should be given to the driver having seats on the right side of the vehicle (in case of side-by-side seating) or to the front driver (in case of front & rear seating).

All the rotating parts must be in the proper covering & fastened with lock nuts. Steering System can be controlled by using mechanical linkages, gears, wires or by electronic devices. In case of handlebars used in steering system, the handles at lock-to-lock positions must comply with rule 5.8.1.

5.16 Utility Requirement- *REVISED*

Vehicles participating in the event should be capable of carrying a load of 20 kg. Vehicles must be equipped with one utility box of internal dimension at least 16 inches (406.4mm) x 12 inches (304.8mm) (base dimensions) x 8 inches (203.2mm) (vertical height). Utility box must be provided with an openable cover at top. Enough space should be available to open the cover for easy placement of luggage items. Utility box should be strong enough to hold the luggage firmly and must be mounted rigidly on vehicle frame. Hung mountings are not allowed.

The utility requirements will be checked by putting a payload of 20kg in the utility box during 'Drive Excellence Test' only as per rule 8.10.

5.17 Vehicle Integrity

No vehicle may discard any part after the vehicle is in motion. Any vehicle found with unsafe loose parts during technical inspection will not be allowed in the event. The vehicle must have integrated structure to ensure the maximum drivers' & bystanders' safety.

If Technical Inspectors find any type of risk to safety, they may ask to make modifications/ changes in the vehicle at event site.

5.18 Kill Switch

Push-to-off kill switch must be provided on the vehicle. Whole electrical circuit of drivetrain must get dead by pushing off the kill switch. **AT LEAST ONE** kill switch must be easily accessible to each driver. Rotary-to-off kill switches, electric switches, self-retracting switches and MCBs are not acceptable for this purpose.

5.19 In-Vehicle Infotainment System *[Optional for convention format]*

A vehicle must be equipped with at least one of the following infotainment systems. These systems should be mounted using sound engineering practices and cannot be removed after inspections and evaluations.

5.19.1 Music System:

This may be operated by USB/Bluetooth/Disk/Radio/other connectivity. The speakers must not be very loud to distract other participants. If sufficient, only one speaker may be provided for this purpose.

5.19.2 Hands Free Smart Phone Connection:

It is required for 2-way communications for voice calls. The riders must be able to accept or reject incoming calls. Hence the keys/touch buttons/voice command operations should be provided to accept and reject calls. Smart phone functions can be used only for dialing the outgoing calls. Microphone and speaker of suitable specifications should be selected/ designed. Interrupting noise during calls are acceptable to the extent where these do not mix with the caller's voice and both callers are clearly audible to each other.

5.19.3 Dashboard – Revised

A dashboard of at least 4inch screen size should be installed in the vehicle. This screen should be powered with the vehicle batteries. Touch controls may be provided for operation of screen. The screen must be able to operate the pre-loaded videos through USB device/Disk/Phone. The panel should be constructed with light weight but rigid enough materials to bear the mechanical loads in general operations, for example, PVC/Nylon/Polycarbonate sheets can be used. location of this panel is not specified but should be in front of driver.

Vehicle should be equipped with Cyclo-meter.

Additionally, the screen may be utilized to display the information or warning of ADAS features (e.g., Cyclo-computer, Reverse Parking Assist, Speed Alert System, Navigation, Battery Level Indicators, speed/odometer etc.).

5.20 Advance Driver Assistance System (ADAS) *[Optional for convention format]*

Advanced Driver Assistance Systems (ADAS) are systems intended to help the driver in their driving activities. They collect the feedback from surrounding or from the vehicle motion and provide information to driver in form of display of collected data or in form of audio-visual alerts.

At least 2 of the following Advance Driver Assistance Systems must be implemented in the vehicle:

5.20.1 Speed Alert System (SAS)

A speed alert system should provide audible warning to driver when the vehicle speed reaches above 25km/h. The feedback of speed may be taken from cyclo-computer installed in the vehicle or through a GPS bases system or any other suitable sensing device.

A continuous or intermitted audible warning can be provided. If the vehicle is using display screen, the visual warnings may also be provided which are clearly distinguished as a warning rather than a regular speed display.

Teams can use any type of sensing and feedback technology. The design requirements of SAS are not restricted.

5.20.2 Reverse Parking Assist System (RPAS)

Reverse parking assist is a mechanism which gives alert to driver about obstacles on rear side of vehicles during parking in reverse mode. The mechanism shall give an acoustic signal to warn the driver on the obstacles detected in the **monitoring range**. Additionally optical warning system may be provided. One or more proximity sensors may be used for detecting the objects behind the vehicle. Teams may opt to use any other suitable sensors.

In case of camera-based systems, obstacle within monitoring range shall be visible to driver. Additionally acoustic warning or optical warning or both may be provided.

The monitoring range shall be from 0.2 meter to 1.0 meter in horizontal plane from vehicle rearmost surface. Detection shall be checked in the horizontal plane at same height from ground at which the sensing mechanism is installed. Single level warning shall be accepted however, the audible warning systems may be designed to provide the warning in gradually increasing frequency as the distance from objects decreases. The test object will be having minimum 75mm diameter.

5.20.3 Adjustable Headlamp

The adjustments in headlamps should be provided to illuminate the road surface ahead of the vehicle according to vehicle speed or steering angle. At least 2 adjustments should be provided in horizontal plan (during steering) or vertical plane (high beam and low beam adjustment) or both. At this stage, it is not recommended to change the intensity of beams at different settings. Only angle adjustment to focus different part of road surfaces may be provided. The adjustment may be provided through mechanical or electronic adjustments in

single step or multiple steps.

5.20.4 Driving Range Information

The driving range is the distance which the vehicle can travel in remaining charge of battery. The range estimation is done through various parameters such as vehicle speed, recent driving pattern, road grade, traffic topology, remaining battery energy, driving style etc. However, at this stage, it is recommended to estimate the driving range on the basis of driving range and current vehicle speed/recent driving pattern. The driving range should be provided in 'unit of km/h'. The logic and calculations of the driving range should be included in the advance technology report.

5.20.5 Seat Belt Reminder (SBR)

Seat belt reminder provides the alert to driver if they are not wearing the seatbelts while the vehicle is in running condition and attains a minimum speed. An Effi-Que should have the seat belt reminder for at least primary driver. At this stage, it is desired that the warning should be provided by the SBR system when the driver is seated in the vehicle and the electric drive is ON. The warning should be in form of continuous or intermitted audible signals or through visual display on screen or both. It is mandatory to provide signals only when the driver is seated and it must go OFF as soon as the driver is unseated. These are the minimum requirements for SBR system.

Further, the precise inputs may be given to SBR system to activate warning when the vehicle attains a certain speed. The circuit diagram of the SBR system and working principle should be explained in the advance technology report. Teams can use any type of sensing and feedback technology. The design requirements of SBR are not restricted.

Safety and drive Assistance Features:

5.20.6 Navigation – Mandatory

In case teams are using Mobile/Tablet/Ipad for navigation purpose, the device should be clamped with rigid and permanent mounting, which should be non-detachable (only device can be detached) & should not hinder & restrict the movement of Driver Body part, Ingress-Egress for normal vehicle operation.



Figure 7

Clip Type & Snap Type Not allowed, Screw mounting should be used.

5.20.7 Anti-theft mechanism (NEW) – Mandatory

Vehicle thefts are common in most countries around the world. To prevent Vehicles from being stolen, teams should use the ‘Anti-theft alarm system’ or Vehicle Alarm. This device or method prevents unauthorized access to a Vehicle. Hence, the team have to fit such a device to prevent it from being used by an unauthorized person.

The Anti-theft alarm system shall work with the help of sensors installed in and around the vehicle. An impact or the movements outside the vehicle activates the sensors. This, in turn, triggers the Anti-theft alarm system and sounds the alarm, alerts the owner/people. Even, the change in the vehicle’s position can alert the tilt sensor and activates the anti-theft alarm system.

Teams must build the system to protect the vehicle. Teams can use any type of sensing and feedback technology. The design requirements of mechanism are not restricted sensors used with the system should be securely and firmly mounted at designated locations.

5.20.8 Accident Alert System (New) Mandatory

This is improved security systems for vehicles. Its main purpose is to detect an accident and alert to the control room/designated person so the driver can find some help. Teams should make a working system of accident alert with using suitable sensors and equipment’s. The design requirements of mechanism are not restricted. All sensors used with the system should be securely and firmly mounted at designated locations & should be water & dust proof (IP65).

There must be a system in the vehicle to detect any frontal or rear crash of the vehicle and notify the emergency contact number designated (minimum 2) about the location of the vehicle in the form of notification/text message.

The teams should furnish the working mechanism and electric circuit of the system in the form of short report/PPT at the time of technical inspection, The inspector can ask the team to manually demonstrate the efficacy and working of the system.



Figure 8: Overview of proposed system

5.21 Other Electrical & Electronic Devices

5.21.1 Headlamp

The headlamp should be mounted at the front of vehicle to increase the visibility during low or no daylight conditions. Either a single headlamp should be provided at the centre of vehicle width or a set of 2 lamps can be provided on both sides.

The headlamp should be mounted at a height between 450mm and 1200mm measured vertically from ground. Headlamps should be divergent. Any white light emitting device can be used as headlamp. Teams must select the lights of sufficient intensity according to night driving condition. Head lamp ON-OFF switch should be provided.

Recommended specifications: The headlamp should illuminate the region covered by angle 15° upward and 10° downward in vertical plan. In horizontal plane it should cover 45° on either side in case of single headlamp and 45° outward, 10° inward in case of separate headlamps when measured from vehicle longitudinal axis.

5.21.2 Brake Lights

A red brake light should be mounted on rear of vehicle to indicate about braking to other vehicle/s approaching from rear. When the brake is applied the brake light must be clearly visible and appear bright in daylight. The brake light shall be illuminated when the brake system is actuated, and completely extinguished when the brakes are released.

The light should be mounted at a height between 350mm and 1500mm measured vertically from ground. Light must be mounted such that it shines parallel to the ground, not up at an angle, up to a distance of 10 meters. The brake light must turn on during the brake test and it must be activated immediately when the brakes are actuated.

5.21.3 Turn Indicator

Amber color turn indicators will be provided at front and rear both. The indicators for left and right side should be separately identified. The flash-light frequency shall be 90 ± 30 per minute and it should be same for all indicators. Same side indicators may flash simultaneously or alternatively. Operation of indicators can be done through lever type switches, toggle switch or push button or rotary type switch can be provided.

The lateral distance between left and right indicators should be at least 800mm and these should be symmetrically placed from the vehicle longitudinal plane. Mounting height shall be between 350mm and 1500mm measured vertically from ground.

Turn indicators should be circuited and mounted in such a way that they can be used as a hazard light as well. If the vehicle is under the breakdown or not able to move during the endurance run, the hazard lights must be activated immediately to warn other vehicles approaching them.

Recommended specifications: The indicators should be visible up to an angle of 80° outward

and 20° inward in horizontal plane when measured from vehicle longitudinal axis.

5.21.4 DRL (Day time Running Light)-New

DRL should be provided at the lower part of front members. Height between 450mm to 700 mm below the Headlamp, DRL allows other drivers to see you on the road which decrease the chances of collision, DRL is start when your vehicle power is ON or when the parking brake Activated, 2 lamps can be provided on both sides.

Any light emitting device can be use as DRL with sufficient efficiency.

5.21.5 Battery and Range Indicator

Battery and range indicator shall provide the visual indication of the battery's state of charge. This indication is required in at least 4 levels. The indication can be displayed in either analogue or digital form (such as LEDs of same or different colors, a digital screen showing percentage/bar icon/text etc.). The display should be given in from of primary driver without restricting the field of view.

Optionally, a visual or audible warning may be given if the battery state of charge goes below a threshold level.

5.21.6 General Requirements of Electrical System

- Lights, Connectors, sensors, ICs and wires etc shall be rated as per AIS/IS/SAE/IEC or another equivalent standard. Datasheet should be presented to judges for verification.
- All connections and terminals shall be insulated to avoid electrical shock and should be securely attached to vehicle structure.
- All recommended specifications are to support teams in selection of components and proper installation. These are not mandatory for Effi-Que 2020-Advance Effi-Que Format.
- The power supply to Head Lamp, Turn Indicators, Brake lights and USB Charging Ports can be done through battery of electric drive train or a separate battery.
- It is recommended to provide a panel (referred as Instrument Panel or Dashboard) in front of driver such that all electronic controls and displays can be attached to this panel. The panel should be constructed with light weight but rigid enough materials to bear the mechanical loads in general operations, for example, PVC/Nylon/Polycarbonate sheets can be used. Dimension and location of this panel is not specified.

5.22 Fasteners

All fasteners used in the systems must be captive; defined as requiring NYLON locknuts, cotter nuts or safety wired bolts (in blind applications). Lock washers or thread sealant do not meet this requirement.

5.22.1 Fastener Grade Requirements

All bolts used in the system must meet SAE grade 5 or metric grade M8.8.

5.22.2 Thread Exposure

All threaded fasteners used in vehicle must have at least 2 threads showing past the nut.

5.22.3 Socket Head Cap Screws

Socket head cap screws, also known as “internal wrenching bolts” or “Allen head bolts” used, must have the bolt head, clearly marked with the letters “NAS”, “12.9”, or “10.9” or high-strength metric fastener.

5.23 Drivers’ Equipment

Both drivers must wear the well fitted cyclist helmets with an integrated (one composite shell) belt to tighten the helmet. Also wear the knee pads and elbow pads and shoes during all dynamic events of the competition.



Figure-7(a)



Figure-7(b)

5.24 Vehicle Identification

All vehicles are required to have proper display of identity of vehicle. Vehicle identification includes **Vehicle Number, Team Name and College Name**. If vehicle identification is lost or obscured, the vehicle will be removed from the competition until this is repaired. Vehicle Identification items must be clearly visible from both sides of vehicle.

5.24.1 Vehicle Number

The vehicle number must be of at least 6 inches (152.4mm) height and 1 inch (25.4mm) line thickness (font thickness). This number will be allotted by the event organizers to all the teams participating in the final event. The number must be clearly displayed on all four sides of the vehicle. It should be vertically placed to ensure its maximum visibility for the purpose of identification & scoring.

Numbers can be placed in form of protrusions, cut-outs, reflective stickers of proper colour (excluding white) etc. Painted numbers are not allowed. The vehicle may get disadvantage in scoring such as lap counting etc. if a vehicle number is obscured during the events.

5.24.2 College Name

College name must be displayed in full or initials at least one place on vehicle which is easily visible from the front and it must be of minimum 2 inches (50.8mm) height.

5.24.3 Logos

Logos of SAE NIS and event sponsors will be provided at the event site. This must be displayed at both sides of the vehicle. Teams can also display their team sponsors logo but it should not affect the visibility of vehicle number and event logos.

5.25 Prohibited Items/ Practices

5.25.1 Vehicle Items/ Accessories

Vehicle should not have any sharp edges which can hurt the drivers and others. The use of horns and bells is **prohibited**. Vehicle body should not have any reflective surfaces or reflective paint. Use of side view mirrors is allowed but they should be accommodated within the maximum vehicle dimensions.

Sealants should not be used for mounting components and to cover the weld joints. Any type of hazardous or explosive materials must not be used in the vehicle.

5.25.2 At Event Site

The teams cannot carry any type of energy drink, liquors, alcohols or energy boosting drugs at the event site. If any team found violating this rule will be disqualified with immediate effect and that college/university will suffer a ban of next 1 more year from participating in the event.

Any kind of misbehave with event officials, volunteers and other team members etc. must be avoided. Any participant must not indulge in the tampering of event properties, tracks etc.

5.26 General Requirements for Mounting Tabs – **NEW**

Any mounting tabs in the vehicle shall comply with the requirements as specified under this rule.

- Any tabs utilized in mounting of components shall have a minimum thickness of 2.3 mm (0.090 in) Minimum weld length for tabs used in mounting of seat, seatbelt, motor will have at least 38 mm (1.5 inch) of weld length per tab. All other tabs will have minimum 25.4 mm (1.0 inch) of weld length per tab.
- Mounting Tabs shall not visibly deform when a load is applied.
- The average distance from the edge of tab hole to the main tab weld line shall not exceed 25.4 mm (1.0 inch).
- Tabs will be welded on both sides.
- The edges of tabs shall be rounded to avoid injuries due to sharp edges.
- Any cut or notch should not be present in the tabs.
-

5.27 Mirrors: -

5.27.1 Rear View Mirror:

Rear View Mirror is a flat mirror designed to allow the driver to see rearward through the vehicle's rear window (rear windshield).

Specification- Dimension is in the range of 6"-8" length, 2"-4" width, Placing should be anywhere inside the vehicle in front of the driver side with a minimum gap of 600mm from the Driver head restraint

5.27.2 Side View Mirror:

A side-view mirror (or side mirror) placed on the exterior of vehicle (Both side) for the purpose of helping the driver to see areas behind and the sides of the vehicle, outside the driver's peripheral vision. It should be accommodated within the limit of vehicle specification with extension of 3" to 6" each side. Mirror should be convex type of any shape and can accommodate a template of diameter 3 cm. Mirror should be rigidly mounted on the frame.

5.28 Feature List for various segments of the event.

Teams may use the below table as a checklist to ensure the list of essential features are implemented / incorporated in the system.

Essential Features	3W Conv Efficycle	3W Advanced Efficycle	4W Effi-Que
Rear View Mirror	•	•	•
Side View Mirror			•
Parking Brakes	•	•	•
Foot Operated - Brakes and Accelerator Pedal			•
BMS [Mandatory parameters]		1	2
Safety & Driver Assistance Features		•	•
Pedal Assist			
In-Vehicle Infotainment [Mandatory system]		1	1
ADAS [Mandatory parameters]		1	2
Accident Alert System			•

SECTION C - DRIVER RULES

6.1 Rider Clothing & Safety

- Clothing intended for cycling or to decrease wind resistance is allowed (skin suits).

- Driver is advised NOT to wear loose clothing during the dynamic events.
- Each driver MUST wear cycling helmet, cycling jersey, full length trousers, shin, elbow and knee guards and running shoes. Shorts/nickers are not allowed.
- The riders to be secured to their vehicles by seat belts, subject to requirement and decision of inspecting authority
- The vehicle can be equipped with a cyclist' water bottle for driver.
- Riders should have their eyes protected while driving either by safety glasses.
- Riders are required to wear shoes and gloves while driving. Use of knee and elbow guards and shin guards is compulsory.
- All moving parts such as chains, idlers, gears etc. should be provided with guards to protect the driver from injury.

6.2 Rider Rules

- A rider cannot push any other person or vehicles during the event. An EfficycleF may not receive pacing of any form from external source.
- A rider may not ride a vehicle with a flat tire or other mechanical problems that the Event Officials seem unsafe. The rider must stop or proceed on foot thereon with the vehicle until it is repaired.
- A rider may proceed on foot along the track as long as the vehicle is present on track (carried, dragged, or pushed). A rider separated from his vehicle may not proceed along the race route, but may travel backward by any means along the route.
- Riders must not block or impede the progress of other vehicles.
- During all the tests same driver shall drive the vehicle. Only in case of some injury extra driver can replace the injured driver with prior acceptance from Event Officials.
- Drivers MUST comply with the instructions of the track volunteers & announcements. Drivers can perform trial runs at the designated practice area only. If any vehicle found performing trials or over speeding etc. at the other places, then it may be penalized.
- **Vehicle Movement:** Drivers are allowed to drive the vehicle only after clearing Technical Inspection. Vehicle should be pushed, at walking speed, by other team members in the areas other than event course and practice area.

SECTION D - REPORTS & DOCUMENTATION

There are 2 Types of Events planned by SAE NIS i.e. Physical Event or Virtual Event, details are as follows:

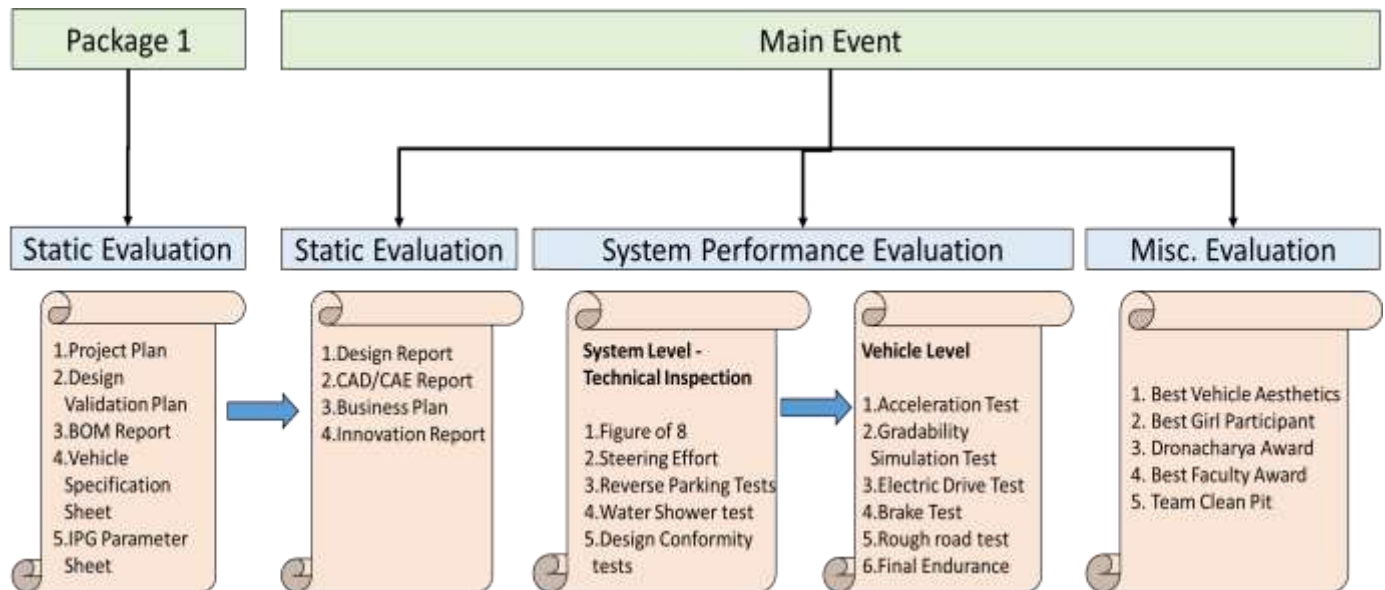

Note: SAE NIS will make official declaration for event format every year

7.1 Reports Submission & Deadlines – Physical Event

All teams are required to submit the following documents in 1 package as per document formats released by Technical Committee:

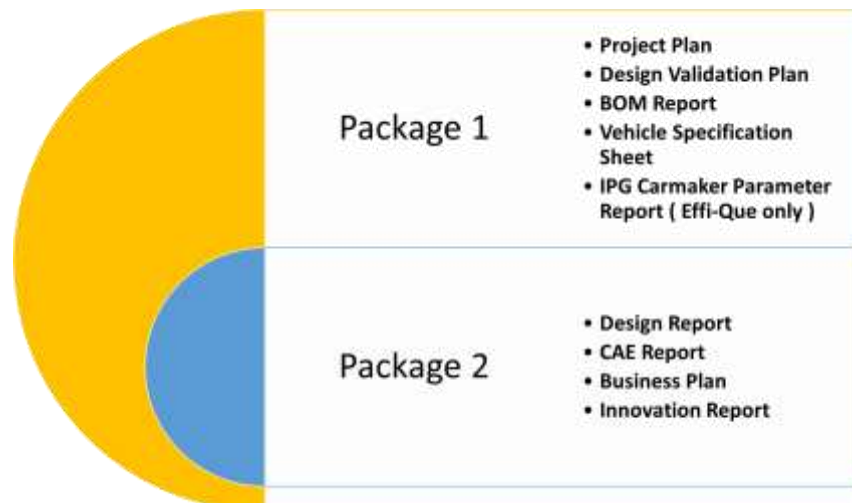

Sr No.	Project Activity	Deadline
1.	Document Package-1 Submission	30-Sep-2022
2.	Vehicle Readiness and running vehicle video submission	30-Sep-2022
3.	Documents Main Event Submission	30-Oct-2022
4.	College Level Technical Assessment	30-Sep-2022 to 20-Oct-2022

The deadline will be 1700hrs on each date of submission.

Document should be submitted through email with following subject line:

“Team ID_Package-#_ Rev# “

7.1.1 Design Readiness

At the time of design report submission, all design related work must be complete. However, teams can start the prototype work, parts procurement and the actual vehicle fabrication prior to design report submission.

7.1.2 Vehicle Readiness - **REVISED**

The vehicle must be 100% complete by 30-Sep-2022. Teams are expected to finish all type of design & fabrication work by this date. After completion of vehicle, teams must undertake extensive design validation & testing of vehicle in-house. During this period, college level technical assessment will also be performed as mentioned in rule 7.4 below.

7.1.3 Running Vehicle Video Submission- **REVISED**

All teams need to submit the video of their vehicle in running condition by **30-Sep-2022**. The guidelines and procedures will be informed separately. Upon late submission of video, the penalty of 2 marks per day will be applied to team’s overall score in main event.

7.2 Late & Early Submission of Document Package

Every team must adhere to all the deadlines mentioned above.

7.2.1 Penalty for Late Submission - **REVISED**

- A penalty of 5 marks per day shall be levied for late submission up to maximum 100 marks for each document package. This penalty will be deducted from the overall team score in the event.
- After non-submission of documents till 20 days from submission deadline given in rule 7.2, team will be barred to participate in the related event. Hence teams are advised to submit the documents in advance to avoid any difficulties during last

minute submission. The penalty will be applicable for non- submission, partial submission or document submission in wrong formats.

7.2.2 Early Submission Advantage

Upon early submission of document package an advantage of 5 marks per day will be added up to maximum 25 marks for each document package. These advantage marks will be added in the overall score of team in main event.

7.3 College Level Technical Assessment

7.3.1 Procedure

Technical Assessment is intended for evaluation of team's readiness for the participation in event. A college level technical assessment of each team shall be conducted before main event. A technical assessment team (having one or more technical inspectors), appointed by Effi-Cycle Technical Committee, will visit the institute and perform necessary inspections. The overall objective of the assessment is to ensure the quality of vehicles and team's preparation for participation in the competition.

7.3.2 Requirements

During technical assessment vehicle must be completely ready as per the rulebook requirements. All the documentation, driver equipment and other particulars required for event shall be checked by an inspector. Technical Inspectors shall thoroughly inspect the vehicle in the same way as it will be performed during the event. Some dynamic tests may also be performed which necessarily includes **at least brake test and figure-of-8 test**.

7.3.3 Feedback of Technical Assessment Team

Teams must take this assessment positively because the feedback given by the inspectors will help them out in making required improvements in the vehicle. Teams may discuss problems faced in vehicle performance, event strategies etc. with the inspectors assigned to them. Inspectors may also suggest some modification in the vehicle.

A report of overall technical assessment will be sent by the assessment team to Effi-Cycle Technical Committee.

7.4 Disqualification from Participation

Performance of teams will be monitored in terms of reports submission, quality of reports etc. If there is any excessive delay or no submission of document packages mentioned in rule

7.1 above, teams will be intimated about their poor response. If any team's performance is found very poor even after intimation, then it may be disqualified from participation in final event. Teams shall be solely responsible for these issues.

Teams may also be disqualified if it is felt during the college level assessment that the vehicle shall not be ready for the participation by the time of start of competition.

Sr. No.	Possible Cases	Actions
1.	Non-Submission/delayed submission of Document Packages	Upon reaching total 200 marks penalty against delay in submission of document packages, team may be disqualified from participation in main event.
2.	Vehicle not ready at the time of inspection and completion not expected till start of event	Team may be disqualified from event.

SECTION E - EVENTS & PROCEDURES

8 Main Event

There will be following categories of events:

8.1 Static & Dynamic Inspections

1. 'Figure of 8' Test
2. Electric Drive Inspection
3. Brake Test
4. Steering Effort
5. Reverse Parking Test (on gradient & with parking assist sensors)
6. Water shower test
7. Ground Clearance test (static & dynamic)
8. Build Quality and Rule/Safety Compliance Check

8.2 Dynamic Events

1. Acceleration Test
2. Gradient Simulation Test
3. Rough Road Test
4. Electric Drive Inspection & Energy Regeneration Test
5. Endurance Run

8.3 Static Events

1. Design Evaluation
2. Business Plan Evaluation
3. CAE Evaluation
4. Innovation & Technology Evaluation

8.1 Static & Dynamic Inspections

All vehicles shall undergo the static & dynamic inspections. Vehicle must clear all the inspections to proceed for all the dynamic events. Any team who fails to clear technical inspection round will not be allowed to participate in the dynamic events further. **However, teams can participate in static events without clearing the inspection rounds whereas teams shall not be entitled for any award in such cases even if the scores in static event are highest.**

8.1.1 'Figure of 8' Test

'Figure of 8' test will be done to ensure the driving capabilities of driver on a maneuvered path and also the dynamic stability of vehicle. There will be maximum specified time limit for the completion of this test. The track layout is given in below figure.

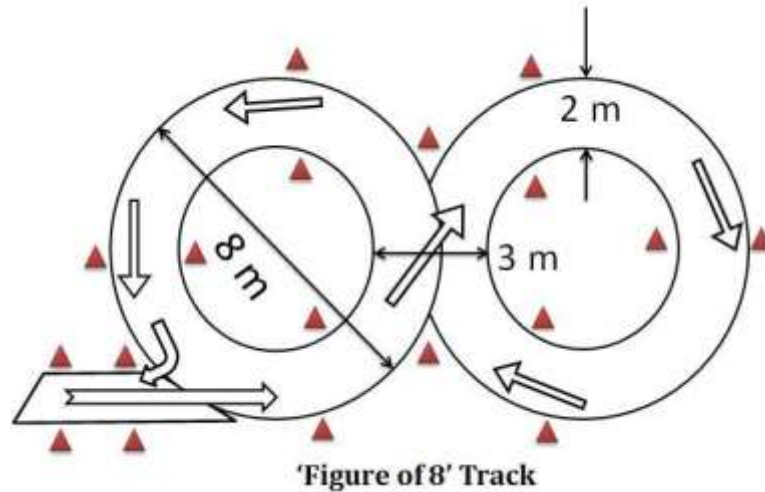

8.1.2 Electric Drive Inspection

1. Electric Drive Inspection will be done to check the compliance of battery & motor specification with the criteria set in the rulebook.
2. It will be ensured that there are no Electric safety hazards due to electric short circuit, battery leakage or poor component mountings etc.
3. Without passing electric drive inspection, teams will not be allowed to participate in the event.
4. *Electric-Drive OK* sticker will be issued to vehicle passing the electric drive inspection test.
5. **For Eff-Que:** A shower test will be conducted for powertrain components. Shower of water will be sprayed on the vehicle for 60 seconds and further after 30 seconds, insulation resistance will be measured.

8.1.3 Brake Test

1. Brake Test will be performed to ensure the maximum braking performance of vehicle in case of any emergency during the dynamic events.
2. Vehicle will be asked to attain a speed of 30 km/h within a distance of 50 meter and then to apply brakes. Vehicle must stop within the distance of 4 meter after applying brakes.
3. After successful completion of brake test, '**BRAKE TEST OK**' sticker will be issued by Brake Test judges.

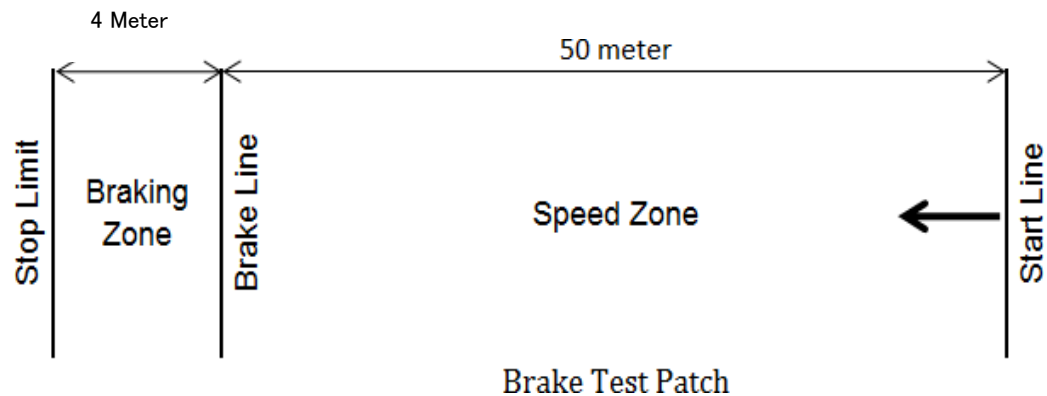

8.1.4 Steering Effort Test

The aim of this event is to conduct an assessment of vehicle's steering force required by the driver to maneuver the vehicle in any direction as well as the compliance with the rulebook parameters and general safety requirements.

8.1.5 Reverse Parking Test

- **On Gradient**

The aim of this event is to conduct an assessment of vehicle's capability to maneuver the vehicle in reverse direction on a slope and hold the vehicle on the slope as well as the compliance with the rulebook parameters and general safety requirements.

- **With Reverse parking sensors**

The aim of this event is to conduct an assessment of vehicle's capability to maneuver the vehicle in reverse direction using the indications/alerts given by the reverse parking sensors as well as the compliance with the rulebook parameters and general safety requirements.

8.1.6 Water Shower Test

- Vehicle will be tested by exposing to spray for a minimum of 5 minutes.
- Vehicle pass when there is limited ingress with no harmful effects. [subjective evaluation to be done by the evaluator], however there should be no ingress near battery/motor area .

8.1.7 Ground Clearance Test

(Refer 5.7) All rigid parts of the vehicle (both rotating and non-rotating) must have minimum 150 mm & maximum 220 mm clearance from the ground when measured with the driver in normal riding conditions.

Aim : To evaluate the above mentioned ground clearance in 2 conditions :

- **Static –**

Checking the ground clearance when the vehicle is on the flat surface and is completely standstill.

- **Dynamic**

Checking the ground clearance when the vehicle is run on a speed breaker of 100mm height with a speed of 5kmph. No interference / touching of the chassis shall occur with the speed breaker.

8.1.8 Build Quality and Rule/ Safety Compliance Check

Aim

The aim of this event is to conduct an assessment of vehicle's build quality as well as the compliance with the rulebook parameters and general safety requirements.

Evaluation Procedure

The vehicle along with the compliance check-sheet will be presented to the panel of Technical Inspectors. The vehicle will be thoroughly checked on parameters including but not limited to:

- Compliance with rulebook parameters
- Compliance with general safety parameters
- Vehicle Layout & Integration
- Quality of weld joints
- Quality of machined parts
- Ergonomics

8.1.9 Inspection Stickers

1. After successful completion of all rounds of technical inspection, '**Safety CHECK OK**' sticker will be issued by the **Effi-Que** Technical Committee.
2. Vehicle must carry these 3 stickers issued during the various stages of Technical Inspection such as '**Safety Check OK**', '**Electric Drive OK**' and '**BRAKE TEST OK**' during the whole event. It will be allowed to participate in any dynamic event only if all the 3 stickers are present on the vehicle.
3. If stickers on the vehicle are lost or tampered, sole responsibility lies with the participating team and stickers will not be issued again.

8.1.10 Changes in Vehicle after Technical Inspection

1. Any types of changes are not allowed in after the vehicle obtains inspections stickers issued by technical inspectors. Vehicle must participate in the event in **As- OK**

- condition.** No part of vehicle can be changed, modified, removed or replaced thereafter.
2. Any type of repairing/maintenance works may be performed only after the permission of Effi-Cycle Technical Committee.
 3. Effi-Cycle Technical Committee reserves the rights to remove the stickers at any stage of event in case of vehicle tempering or vehicle may be barred from event for certain duration or vehicle may be disqualified depending upon the severity of case.

8.1.11 Workshop Access at event-site

Any vehicle may enter in the workshop area only after permission of Technical Committee officials. Technical Committee reserves the right to provide workshop access after 1st attempt of Safety Compliance Check.

8.2 Dynamic Events

8.2.1 Acceleration Test

Aim

The goal of the Acceleration Test is to provide engineering students an opportunity to demonstrate the maximum acceleration & maximum speed capability of their vehicles in a non-race condition.

Max Permissible speed for Effi-Que: 35 Kmph

Track Description

The course will consist of straight, smooth and level paved surface of suitable width and clear of obstacles, pits, cracks or potholes. Track length will be of 100 meter in time trap zone. Vehicle will have to start from start line marked on track. There will be no separate run-up zone.

Method & Rules

1. Test will be performed with single rider & Luggage weight 20Kgs.
2. Vehicle will be allowed to run on the track only when signaled by the trackjudges.
3. Team will be asked to start from standstill and to cover the distance of 100 meter in the minimum possible time. The time taken to cover the complete track will be noted down.
4. Maximum 2 attempts are permitted per vehicle. The minimum time out of two attempts will be considered for evaluation.
5. In case of vehicle breakdown or rollover on track, departure from track before finish line; that attempt will be considered as void. No other chance will be given in lieu of.

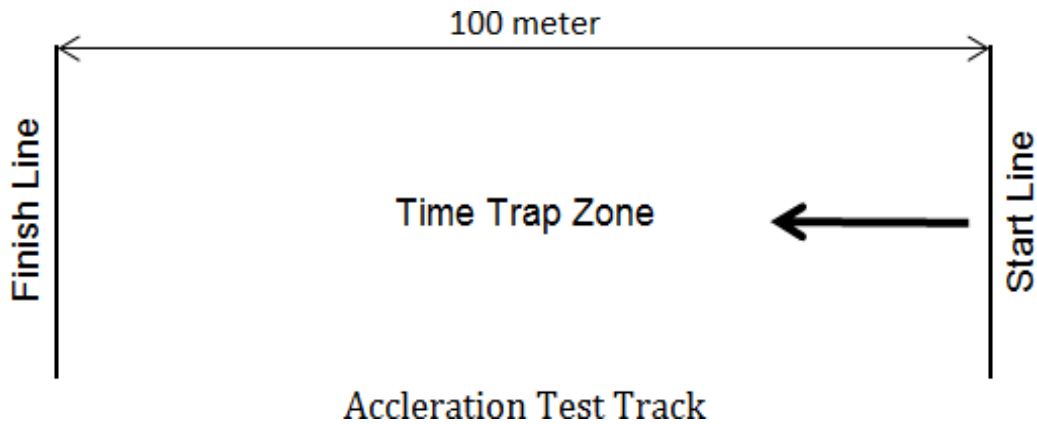

8.2.2 Gradient Test

Aim

The goal of the Gradient Test is to provide engineering students an opportunity to demonstrate capability of vehicles to climb on inclinations in non-race condition.

Track Description

The course will consist of straight, smooth and level paved surface of suitable width and clear of obstacles, pits, cracks or potholes. Total track length will be 50 meters. The track will be a real gradient having maximum slope of 5 degree. Vehicle will have to start from start line marked on track.

Method & Rules

1. Test will be performed with 1 driver & 20 Kgs. Luggage weight for Effi-Que.
2. Vehicle will be allowed to run on the track only when signaled by the trackjudges.
3. Team will be asked to start from start line marked on track from standstill condition and then to cover the complete track in minimum possible time. The time taken by vehicle to cover the distance from start line to finish line will be noted down.
4. Maximum 2 attempts are permitted per team. The minimum time out of two attempts will be considered for evaluation.
5. In case of vehicle breakdown or rollover on track, departure from track before finish line or not reaching the finish line; that attempt will be considered as void. No other chance will be given in lieu of.

8.2.3 Rough Road Test

Aim

The goal of the Utility Demonstration Test is to provide engineering students an opportunity to ascertain the suitability of vehicle in a real-world application such as personal or commercial mobility.

Track Description

The course will be representative of actual roads including various sharp turns, speed breakers and other obstacles etc. Total track length will be minimum 500 meters. Vehicles will have to start from start line marked on track. There will be no separate run-up zone.

At certain part of tracks, it may be required for drivers to get down from vehicle and then restart the journey. Hence teams should plan the strategy of event keeping these conditions in mind.

For Effi-Que Variant: Water wade track will be part of utility demonstration test. This portion of track will be filled with water at certain level.

Method & Rules

1. Test will be performed with only 1 driver wearing all driver safety equipment.
2. There will be 2 attempts for Utility Demonstration Test, both to be performed on separate event days. **Each vehicle has to complete at least one attempt successfully to qualify for the endurance run.**
3. There will be maximum specified time limit for the completion of each attempt.
4. Vehicle will be allowed to run on the track only when signaled by the track judges.
5. Vehicle will be asked to start from standstill and to cover the complete track in the minimum possible time. Time taken to complete the test will be recorded.
6. The minimum time in both attempts will be considered forevaluation.
7. In case of vehicle breakdown or rollover on track, departure from track before finish line or exceeding the specified time limit on track; that attempt will be considered as void. No other chance will be given in lieu of.
8. For touching track boundaries, cones a penalty of 2 seconds will be applied in total course time for each such case.

8.2.4 Energy Regeneration Test- REVISED

The aim of Energy Regeneration Test is to evaluate the performance of the Energy Regeneration System implemented in the vehicle. **This evaluation will be Mandatory for every Team, the score for the Energy Regeneration Test will depend on following parameters:**

- **It should be a working concept & The Power Regenerated should at least:**
 1. Power an accessory
 2. Charge the battery
 3. Brake the vehicle
- **The concept will be evaluated based on the above three categories**
- **If Energy regenerated is extending the vehicle range by storing the energy in the battery <Additional Score of 50 Marks will be given>,**

Regeneration System will be accepted in the fully working condition and must be demonstrated to judges during evaluation. For reference of judges, teams must carry the

following during evaluation:

- Energy Regeneration Report
- Presentation of Regeneration System in form of Hand-made charts/ Power-point Slides/ Videos/ Animations/ Prototype etc.

During the evaluation, vehicle will be subjected to a dynamic test where the energy regenerated by the vehicle during Deacceleration/ braking, will be compared with the kinetic energy present in it before applying the brakes. Teams may be asked questions about the design of system, efficiency, effectiveness etc.

8.2.5 Endurance Run

Aim

The goal of the Endurance Run is to provide engineering students an opportunity to demonstrate the durability of their vehicles in a race condition.

Endurance Run

Teams have to run on an endurance track for specified duration. Laps covered by the teams will be considered for the evaluation of endurance score.

Track Description

Endurance track will be a closed-circuit including lot of turns, bends, gradients and various other obstacles. Total length of circuit will be around 2km. Team will have to line-up in funneling area before the start of event. Vehicle must run on an endurance track for specified duration.

Method & Rules

1. Test will be performed with only Driver.
2. Use of human & electric power both is ALLOWED for hybrid variants.
3. Vehicle must line up according to their position as specified by the Technical Committee. Positions will be declared according to the performances in dynamic events.
4. Vehicle will be allowed to run on the track only when signaled by the trackjudges.
5. The total duration of endurance run will be maximum 2 hours and teams will be asked to cover maximum laps in this duration.
6. If a vehicle breaks down during the run, it should be carried out of the track immediately. Vehicle may appear on the track after complete repair and only after the permission of Technical Inspectors.
7. Laps covered by the teams will be considered for the evaluation of endurance score. Partially completed laps will not be considered for scoring purpose.
8. Vehicles found in unsafe conditions on track will be removed from track with immediate effect.
9. After the completion of endurance run, vehicles will be impounded at parking area for

final inspection. At that time no team member will be allowed in parking area.

Lap Counting and Timer

1. On the blow of siren, vehicles will be allowed to run on the endurance track.
2. At the time of blow of siren; timer will start for all the vehicles (timer at 00:00:00).
3. Lap counting of individual vehicle will be done each time it reaches to the start line.
4. After the completion of event, timer will be stopped (timer at 02:00:00).
5. Total laps covered by individual teams till 02:00:00 condition will be considered for evaluation. Partially covered laps will not be counted.

Durability Advantage (100 Marks)

To prove the durability, vehicles are supposed to be in complete running and safe condition after endurance run. Only teams, which cover 50% or more laps of the maximum laps covered by any team, are eligible for the durability advantage.

All eligible teams will be inspected after the endurance run to evaluate the durability advantage. Any vehicle which is not having any significant breakdown will be awarded with full durability advantage according to the following criteria:

a) Battery Management System & Vehicle Range: <50 Marks>

Battery Management system is mandatory in Effi-Que, To evaluate the usage & optimization of BMS Strategy of participating Teams, following Evaluations to be done:

1. Vehicle Driving Range: To be checked during Durability check by means of Difference in SOC & Total Kilometers covered;

Range Target: 60 Kms (Full charge to Empty Limit as set in BMS strategy)

If the Range of Vehicle is Lower than Target, then Marks will be deducted.

2. Battery SOC / Temperature Monitoring & Display: As a part of BMS Strategy, Monitoring of SOC & Temperature will be mandatory. < 10 Marks >

Accurate display of SOC & Temperature shall be done through Monitor/indicators.

b) Vehicle Drive: Any component of drivetrain should not have any breakdown. Any misalignments in drive are excluded.

c) Wheels and Axles: Any wheel (including axles) should not wobble or deform. Dynamic stability of vehicle will be monitored during endurance run.

d) Braking System: All brakes mounted on wheels should function properly. No breakdown should occur in brake levers, disc, calipers or wires. Brakes in static conditions will be checked.

e) Other Components: All other important components such as frame members, fairing, seats, body covers and other subsystems should remain intact in original position.

Parts	Advantage
Battery Management System (Range, SOC & Temp Indicator)	60 marks
Drive Train	10 marks
Wheels and axles	10 marks
Braking system	10 marks
Other important components & subsystems	10 marks
Total Advantage	100 marks

8.3 Static Events

8.3.1 Design Evaluation

Aim

The aim of the Design Evaluation is to provide an opportunity to the participants to discuss their design methodology, design process with the panel of judges and to highlight the special features of their vehicle.

Evaluation Procedure

Design assessment will be done through Design Report, As-Built Vehicle Report along with the vehicle. Teams will be asked to explain their design methodology, design of the subsystems, material & part selection, safety, calculations and analysis etc. Marks will be given on the basis of team's explanation over such questions asked by the judging panel. The average of marks given by individual judges of the panel will be considered as final marks scored by a team in this event. Use of additional presentation items such as charts, sketches, prototypes etc is permitted.

8.3.2 Business Plan Evaluation

Aim

The aim of the Business Plan is to provide an opportunity for the engineering students to prepare a strategic business model of establishing a firm which can produce their own design at a certain rate (say 2,000 vehicles per year) and market it. Judges can be considered as hypothetical capital investors who can invest into team's business model to support in establishment of that firm.

Presentation Format

Teams are advised to prepare the model by working out on the following points in the presentation:

1. Unique Selling Proposition (USP)
2. Market/Customer Survey (to analyse the product demand)
3. Different concepts & variants

4. Plant layout for mass production
5. Cost of product in mass production
6. Break-Even Analysis (in terms of time & quantity)
7. Return on Investment (in terms of time & money)
8. Marketing strategies (sales & after sales)

Presentation must be in MS PowerPoint format with the file size not exceeding 10MB. Use of promotional videos, charts, graphs, brochures is encouraged, provided that the total time doesn't exceed the specified duration. Other details will be specified on the website.

8.3.3 CAE Evaluation

The aim of CAE Evaluation is to evaluate teams' knowledge about CAE. This evaluation will be done only for those teams who apply for the CAE Award. **The score for the CAE award evaluation will not be included in the overall event score.** Nominations will be registered prior to main event. However, submission of CAD/CAE Report as per rule 7.2 is mandatory for all teams.

For reference of judges, teams must carry the following during evaluation:

- CAD/CAE Report
- All CAD Models related to frame and different subsystems
- CAE Models and analysis reports

During the evaluation, teams may be asked questions about CAE procedures, pre-processing, post-processing, optimizations, validation of CAE Results, calculations for loads, selection of material, optimization of design etc.

8.3.4 Innovation & Technology Evaluation

The aim of Innovation Evaluation is to evaluate the innovations implemented by the teams in their vehicles. This evaluation will be done only for those teams who apply for the Innovation Award. **The score for the Innovation award evaluation will not be included in the overall event score.**

Innovations will be accepted in the fully working condition and must be demonstrated to judges. Technologies already functional in Indian Automotive Industry will not be accepted; however the new application of existing technologies will qualify this criterion.

For reference of judges, teams must present the Innovation Report comprising of following details during innovation evaluation:

- Concept of the innovation implemented in vehicle
- Feasibility of the mass production for implementation on big scale
- Supporting data, calculations, drawings etc.

- Scope of the innovation and their applications in the automotive industry

➤ Technology Evaluation

The evaluation of advance technologies and features will be done by a judging panel when the vehicle is presented before them in completely ready condition. The average of marks given by individual judges of the panel will be considered as final marks scored by a team in this event. The evaluation will be done on the basis of following parameters:

- System Design
- Correctness of calculations
- Effectiveness of system
- Ease of implementation at mass level
- Schematic Layout, drawings, sketches etc.

Weight Measurement & Light Weight Score (50 Marks)

Weight of the vehicle will be measured after all rounds of inspection and quality checks. The Vehicle having **weight within 120kg** will be entitled for light weight score.

Vehicle with minimum weight will be awarded full 50 marks and vehicles with more than **120kg weight will be given zero marks**. All other vehicles will get a score on comparative basis from 10 to 50.

Competition Penalties

Sr. No.	Case	Penalty
1.	Violation or Breaching of Event Protocols	30-50 marks for each case, Depending upon
2.	Misconduct with volunteers or officials	100 marks
3.	Unauthorized entry in restricted area or tracks	50 marks
4.	Tampering with vehicle after Tech-OK	100 marks
5.	Intended tampering with tracks or event	50 marks
6.	Unjustified or false protest	50 marks

1. These penalties will be imposed by the Competition Organizers with the immediate effect on occurrence of each case.
2. All penalties will be deducted from overall score not from any individual event scores.

9 Evaluation Matrix & Scores

Efficycle season 13: Virtual cum Physical Event - Evaluation Matrix										Segment Wise Score		
Evaluation	Type	#	Evaluation parameter	3W Conv Efficycle	3W Advanced Efficycle	4W Effi-Que	Score	Section Score	3W Conv Efficycle	3W Advanced Efficycle	4W Effi-Que	
Package 1	Static Evaluation (Part 1)	1	Project Plan	•	•	•	50	300	50	50	50	
		2	Design Validation Plan	•	•	•	50		50	50	50	
		3	BOM Report	•	•	•	50		50	50	50	
		4	IPG Car Maker Simulation			•	50		0	0	50	
		5	IPG Model Parameters report			•	50		0	0	50	
		6	Vehicle Specification Sheet	•	•	•	50		50	50	50	
Main Event	Static Evaluation (Part 2)	7	Design Report	•	•	•	100	400	100	100	100	
		8	CAD/CAE Report	•	•	•	100		100	100	100	
		9	Business Plan	•	•	•	100		100	100	100	
		10	Innovation report	•	•	•	100		100	100	100	
	System Performance Evaluation	System Level - Technical Inspection	11	Figure of 8	•	•	•	50	500	50	50	50
			12	Electric Drive Test	•	•	•	50		50	50	50
			13	Brake Test	•	•	•	50		50	50	50
			14	Steering Effort			•	50		0	0	50
			15	Reverse Parking [gradient]	•	•	•	50		50	50	50
			16	Reverse Parking [rear parking sensors]			•	50		0	0	50
			17	Water Shower Test	•	•	•	50		50	50	50
			18	Ground Clearance Static & Dynamic	•	•	•	50		50	50	50
			19	Vehicle Specification Rulebook Check	•	•	•	100		100	100	100
	System Performance Evaluation	Vehicle Level	20	Acceleration Test	•	•	•	100	900	100	100	100
			21	Gradability Simulation Test	•	•	•	100		100	100	100
			22	Rough Road Test	•	•	•	100		100	100	100
			23	Energy Regeneration Test	•	•	•	200		200	200	200
			24	Final Endurance	•	•	•	400		400	400	400
	Misc. Evaluations		25	Vehicle Aesthetics	•	•	•	-	-	-	-	-
			26	Best Women Participant	•	•	•	-		-	-	-
			27	Dronacharya Award	•	•	•	-		-	-	-
			28	Best Faculty Advisor	•	•	•	-		-	-	-
			29	Team Clean Pit	•	•	•	-		-	-	-
	Additional Scores		30	Light weight score	•	•	•	50		50	50	50
31			Energy Regeneration - Range Extension		•	•	50	0		50	50	
32			Endurance - Durability Advantage	•	•	•	100	50		100	100	
TOTAL EVENT SCORING									2000	2100	2300	

10 General Rules for Competition

10.1 Drivers Training

All drivers who will participate in the dynamic tests must attend the Drivers Training sessions when called on event days. The trainings will clarify operating procedures, signals etc. and it will identify tracks features, hazards, landmarks and penalties which can be applied on team in case of not driving safely.

In unavoidable situation when the drivers cannot attend the training, any other team member may attend this training and explain to driver. If the training is not attended by any team, their vehicle will not be allowed to participate in dynamic events.

10.2 Protest

Participating teams are assumed to have full faith in the Rulebook and Event Procedures and hence any team may not protest against particular event procedures or the rulebook interpretation. In case of any objection/misunderstanding with the judgment taken during the event or any issue with the competitors, teams may discuss with the event organizers. But all such complaints will be taken in account for official consideration and further action only when submitted in written form, addressed to Effi-Que Organizing Committee.

Protest must be filed within 2 hours of the completion of related event. Decision of event organizing committee will be considered as final. Team must ensure that if complaint is found to be false or unjustified; 50 marks will be deducted as penalty from total score of the complaining team.

10.3 Workshop Facilities at Event Site

1. Each team will be allotted a pit in the Pit Area to park their vehicle and to keep the tools and spare parts.
2. General workshop facilities like welding machines, cutting tools etc. may be provided at event site, but teams are advised to bring their own necessary tools to avoid any difficulties.
3. MIG welding facility shall also be provided at the event site. Priority of usage shall be given to vehicles using alternate frame materials requiring MIG welding facility.
4. Power supply & adequate illumination will be provided in pit area.
5. **Workshop access will be given with the permission of Technical Committee.**

10.4 Vehicle Presence at Event Site

Vehicle must enter to event site before the start of technical inspection or as specified by the event organizers. Vehicle must be parked in the assigned pit after the closing of events each day. Vehicle is not allowed to go outside the event site in any case before completion of the

complete event except in case of voluntarily withdrawing participation from event. If vehicle found outside the event premises, it will be disqualified from participation with immediate effect. Teams must carry all necessary arrangements to event site with them.

10.5 General Guidelines

- a) Teams may be allotted a sequence and a time limit for inspection, static and dynamic evaluation. Any team failing to appear as per schedule will be considered not participating in that event. Hence teams must keep their vehicle in proper running condition and be ready for evaluation as per given schedule.
- b) In case of tie-break, decision of Technical Committee will be considered final and will be agreed to all participants.
- c) Technical Committee reserves the right to change the event guidelines, procedure and schedule etc for smooth conduction of event.

SECTION F- DOCUMENTS FOR MAIN EVENT

11 Additional Documents (other than Package documentation) Required for Inspections & Evaluations- **REVISED**

All teams must carry the following documents to the event site for vehicle inspection, static events and dynamic events.

	Document	Soft Copy	Hard Copy
1.	Material Testing Report for all frame materials	Y	Y
2.	Photos and videos of In-house fabrication	Y	--
3.	Copy of any special permission related to vehicle / rule compliance or clarification as received from Efficycle.technical@saenis.org	Y	--
4.	Circuit Explanation Diagram for each electrical and electronic circuit to understand the working mechanism during evaluation process	Y	Y

12 Document Required for Team Registration at Event Site

- Original Hard Copy of Team Registration Form with sign and stamp of college authorities.
- Original copy and Student ID cards of all the team members issued by college.
- Valid SAE membership cards of all the team members & faculty advisor.

13 Document Required for Driver Registration at Event Site

Following documents will be required for registration of at least 2 (Two) Drivers, who will drive the vehicle at any time during the competition:

- Valid, government issued driving license of 4-wheeler.
- Copy of Medical insurance

SECTION G - CONTACT INFORMATION

14 Contacts

Details of contacts for official communication are as below:

	Particular	Contact
1.	Registration & General Communication	Efficycle.teams@saenis.org
2.	Technical Queries & Rulebook Clarification	Efficycle.technical@saenis.org
3.	Reports Submission	Efficycle.reports@icat.in
4.	Official announcements & information (through online official channels)	effi.saenis.org , www.facebook.com/groups/EfficycleSAENIS/

© SAE Northern India Section